

MYLOCOSOUND

North American Edition

PREMIUM UNIVERSAL SOUND FOR LARGE SCALE, DIESEL LOCOS & RAILCARS

1. OVERVIEW

- Easy installation using screw terminals with no soldering.
- Uses a TV remote control to adjust the sounds to match the prototype loco.
- Provides five selectable engine sounds which adjust to match the loco speed and load.
- Start up sequence for each engine and three transmission options.
- Seven selectable horns.
- Full remote control of the horn, bell, airbrake, “All aboard” and optional turbocharger.
- Optional brake squeal.
- For track powered DC or DCC or battery powered, radio controlled railways.
- Measures 55mm x 33mm x 11mm.

2. CONTENTS

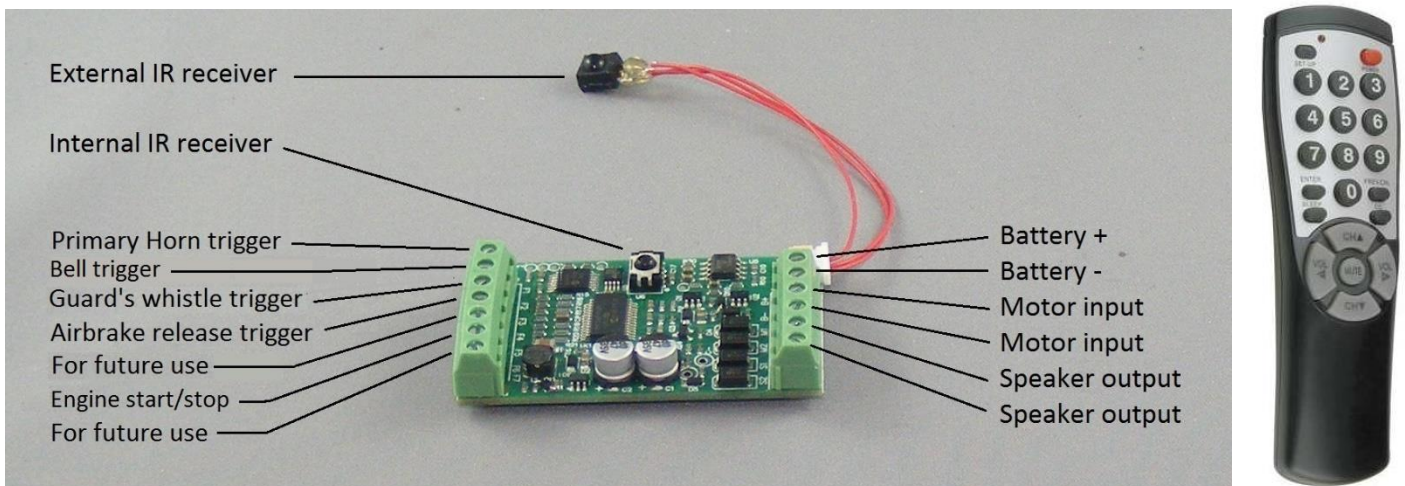

The soundcard generates synthesised sound which is adjustable to reproduce the sounds of most diesel locos and railcars. The terminal connections on the right are necessary for the soundcard to generate diesel sounds which vary with the loco speed and load. The terminal connections on the left trigger the various sounds where the locomotive controller has the appropriate outputs available. The trigger terminals are labelled F1 to F7 and are referred to by these labels in these instructions. For example, “Triggering F1” means to close a contact between the F1 terminal and the Battery negative terminal.

Sounds can also be triggered by a Sony infra-red TV remote control which can be purchased locally. Low cost, universal, TV remote controls are available from most consumer electronics stores and need to be set to Sony coding to work with the soundcard. Although it can be used when running in the garden, the remote control is intended mainly for the adjustment and testing of sounds.

The remote control communicates with the soundcard via two infra-red receivers. One is located on the soundcard and the other is on a flying lead which allows it to be fixed to any external surface of the loco. Adjustments to the sounds can then be made without taking the loco apart to access the soundcard.

3. SPEAKERS AND SOUND QUALITY

The soundcard requires an 8 ohm loudspeaker which is not included. A 4 ohm speaker can also be used but you may cause the soundcard to overheat and temporarily shut down if the volume is very high and the soundcard is in a confined space. Your choice of speaker is highly important because it determines the quality of the sound produced.



1. To get maximum volume, the rated (or RMS) power should be 2 watts. A 1 watt or lower speaker will fall short on volume. Speakers exceeding 2 watts can be used but will not produce any more volume due to the limited output of the soundcard amplifier.
2. The resonant frequency should ideally be below 350 Hz but certainly below 500 Hz. The lower the resonant frequency, the deeper the diesel engine, horn, etc.
3. Use the largest diameter which you can fit in your loco. Two inches is the most popular.



For a better quality sound and more volume, the speaker needs to be baffled. That means that it needs to be built into the front face of an airtight box so that sound is heard only from the front of the speaker and none from the back. The plastic top of a spray paint can is good for making a baffle as shown in the diagram.

A good solution, which ensures high quality sound with lots of deep throbbing bass, is to purchase an 8 ohm impedance external speaker unit for iPod and MP3 music players and remove the two speaker modules, in their enclosures, for use in two locos. These are readily available at consumer electronics stores.



Speakers can be connected to the terminals either way around.

Important Notes

The soundcard is designed for outdoor use and may not work correctly under bright incandescent lights on a workbench. LED lights are okay.

The soundcard is in a “sleep” mode when not in use. Connecting it to power at the B+ and B- terminals will not wake it up. It must also be connected to a motor at the M1 and M2 terminals as well. The small voltage it sees at the motor will wake it up and it will then stay awake for as long as it has power.

4. INSTALLING THE SOUND CARD IN A TRACK POWERED LOCOMOTIVE, DC OR DCC

The soundcard is suitable for use on analogue DC track powered railways on which the following wiring diagram should be used:

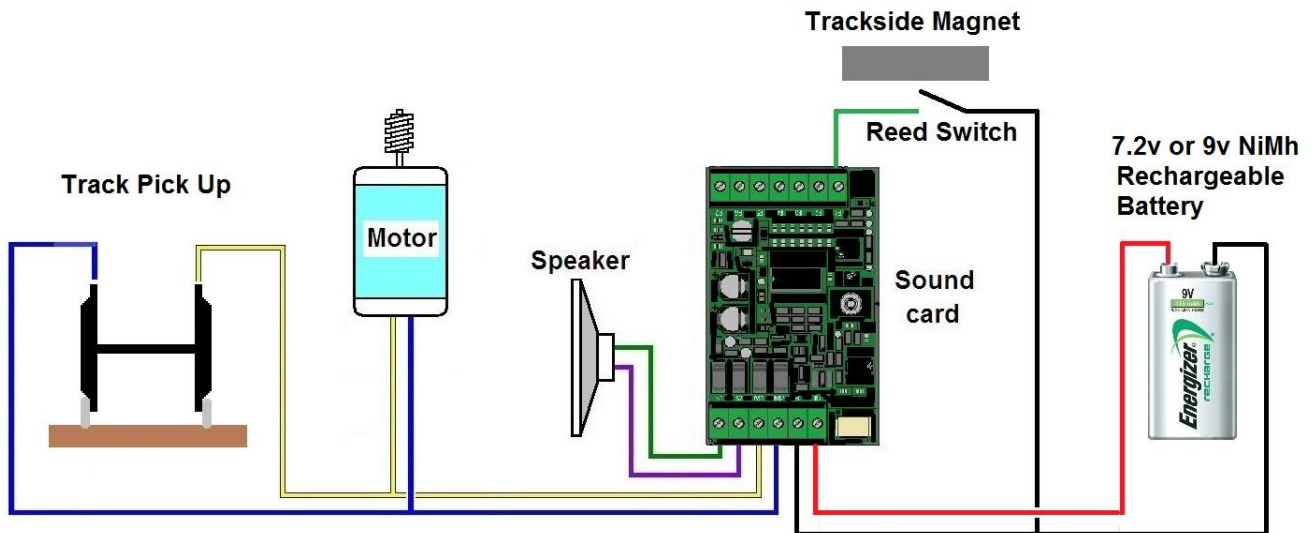

The wiring diagram below shows the connections for the DC jumper board in a Bachmann locomotive.

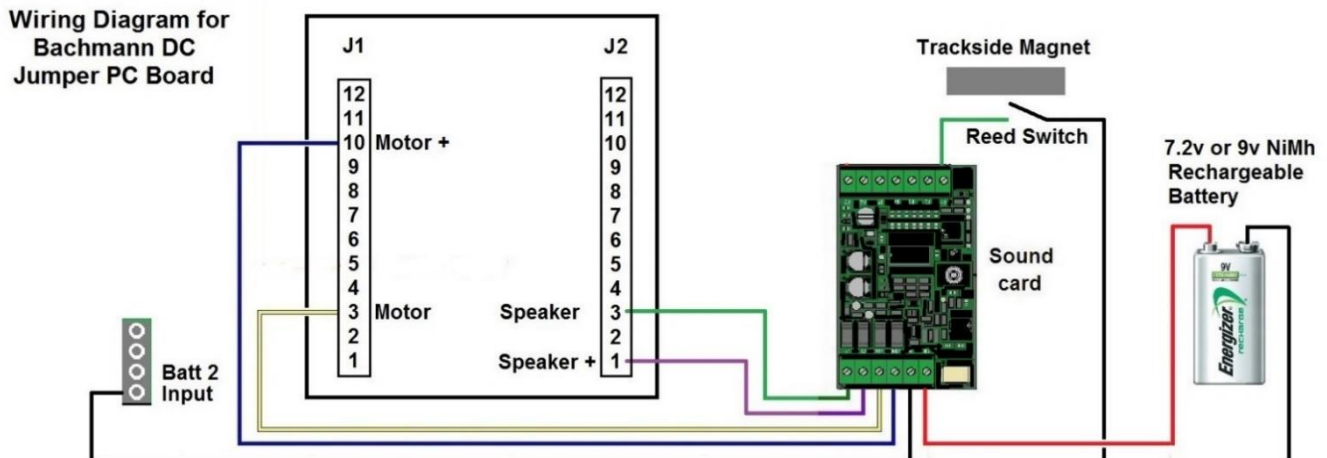

On DCC track powered railways in locomotives using a basic decoder, the wiring is a little different:

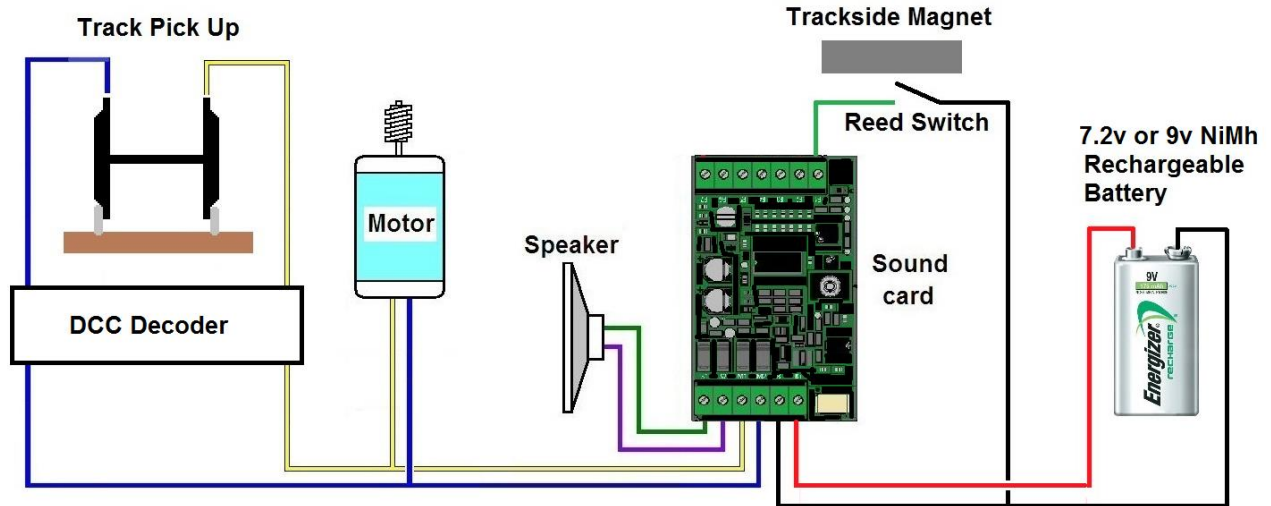

When the motor voltage is below seven volts it is insufficient to power the soundcard. Therefore a 9v volt PP3 or a 7.2v cordless phone battery is used to drive the soundcard and produce sound when the loco is static or moving slowly. This battery will be automatically recharged whenever the motor voltage is at about 1.8 volts higher than the battery voltage so there is often never a need to remove the battery for recharging. However, the battery must be a Nickel Metal Hydride type; Lithium and Nickel Cadmium batteries must not be used.

If your loco has a motor on/off switch, it can be used to recharge the battery while the loco is stopped. Just switch off the motor and turn up the track voltage to at least 11VDC.

Another option is to fit a recharging socket so that the support battery can be recharged, using an external battery charger, without removing the battery from the loco. We recommend using a three pin, panel mounted DC power socket which, when wired as shown, isolates the soundcard when the charger is plugged in.

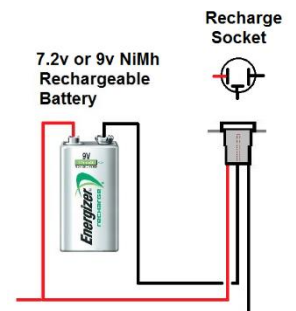

On analogue DC layouts which have pure DC controllers (as opposed to PWM controllers) you may need to give the throttle a bit of a tweak to start the sound. On those layouts, the sound will automatically turn off after one minute of inactivity and another tweak will turn it back on. With the more common PWM controllers and with DCC the sound will turn on automatically and stay on.

When the loco is removed from the track the soundcard will go into a “sleep” mode to preserve the battery charge. A fully charged battery should retain charge for over a year.

Because most DC controllers do not have function buttons, an alternative way of triggering the horn, bell and other sounds needs to be found. The options are:

1. You can set the horn to sound automatically three times a minute when the train is running. Other sounds can also be triggered automatically. This is described in section 8.

2. You can connect the soundcard horn trigger to a reed switch which you mount on the bottom of the loco. Then install magnets in the track where you want the horn to sound eg. at the approaches to a level crossing. The horn will then sound briefly as the loco crosses each magnet.
3. Use the remote control, supplied with the soundcard, to trigger all the sounds as described in section 8. However, infra-red remote controls are not designed for long distance use outside. On an overcast but bright day, the remote control, powered by AA or AAA batteries will probably operate up to three metres away.

Any combination, or all, of these methods can be used.

With DCC, the soundcard is not a decoder and cannot trigger sounds directly from the controller. Therefore the above methods are used to trigger the sounds. Some decoders have a servo output which can be used to trigger sounds from the controller buttons by using a servo switch. They may also have a constant DC power output which can replace the battery if it is in the voltage range 8 to 24 volts. These connection options are shown below:

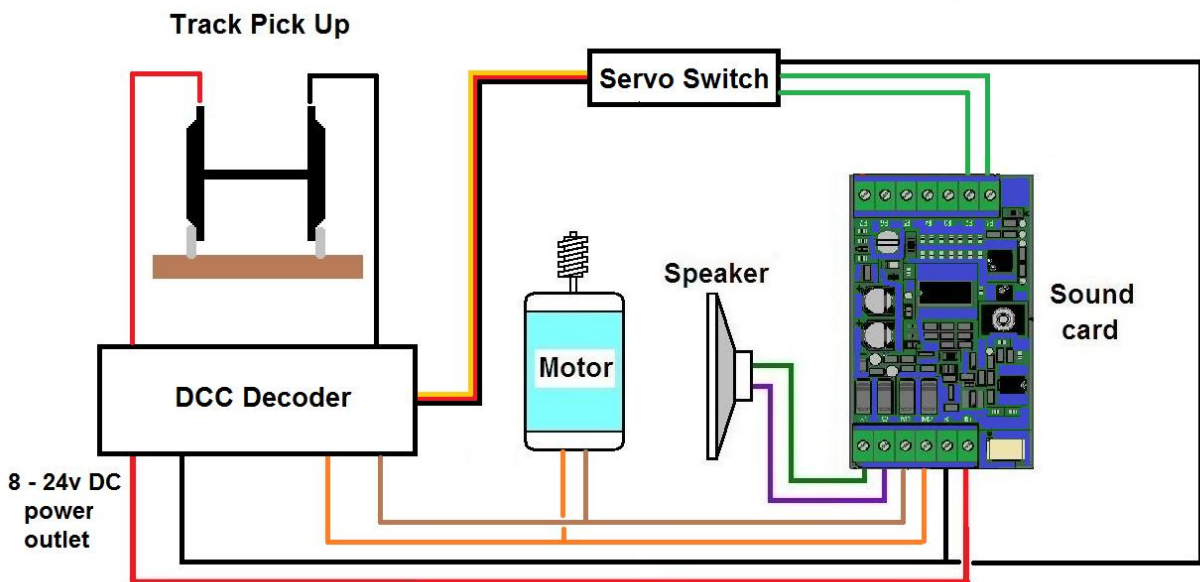

Many decoders also have function outputs which can be used to trigger sounds. However, this is technically difficult and you should only attempt it if you are very familiar with your decoder and the setting of CVs.

Now continue reading at section 6.

5. INSTALLING THE SOUNDCARD IN A BATTERY POWERED LOCOMOTIVE OR RAILCAR

The wiring diagram below shows a typical installation for common types of battery powered radio control systems.

The RailBoss 4 can trigger four sound functions. The fifth and sixth soundcard triggers, the turbocharger and engine start/stop, therefore cannot be radio controlled and will need to be switched on, if required, by the IR remote control or be set to sound automatically.

Wiring Diagram for RailBoss 4

Despatch is "All aboard" and a guard's whistle

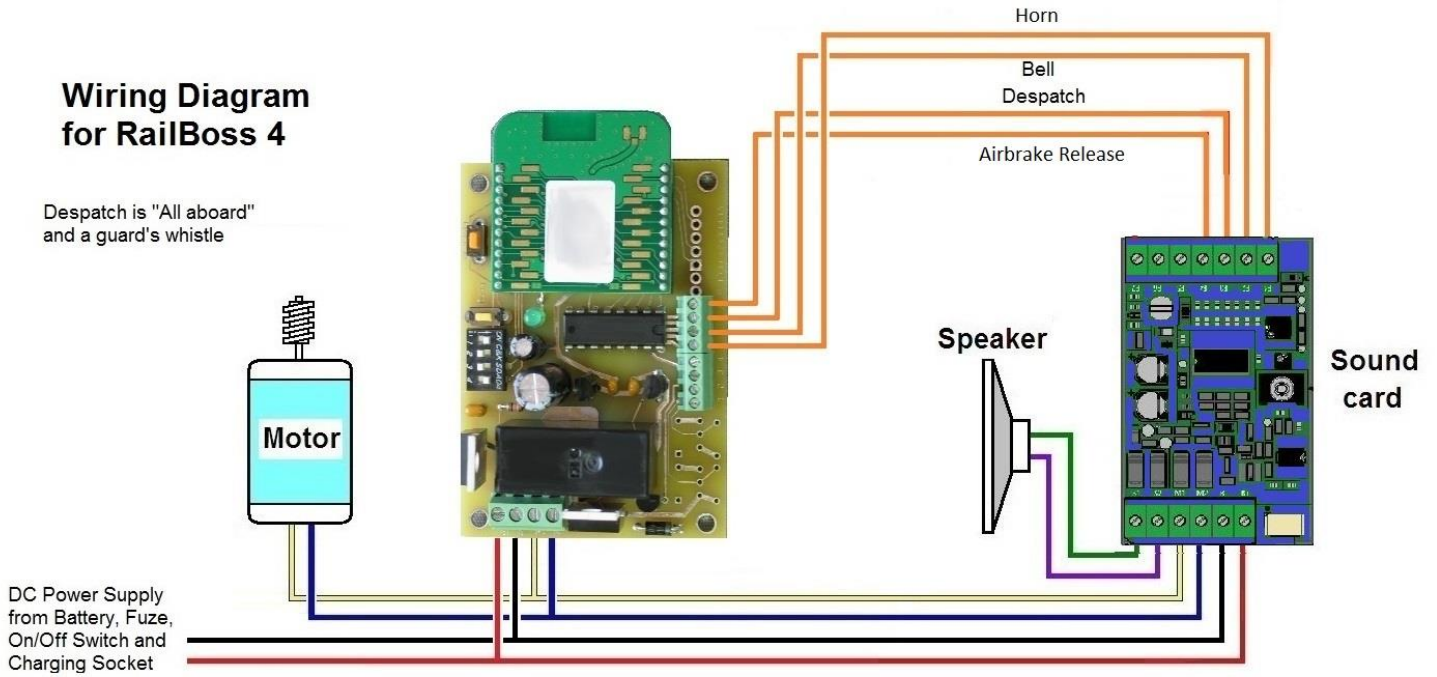

The above wiring diagrams can be seen in colour by visiting the web site at www.mylocosound.com/installs. Also shown are specific wiring diagrams for RCS, Spoerer, Mtronics, Roundhouse and LocoLinc.

The Crest Revolution can trigger all sound functions and is connected as shown in the diagram below.

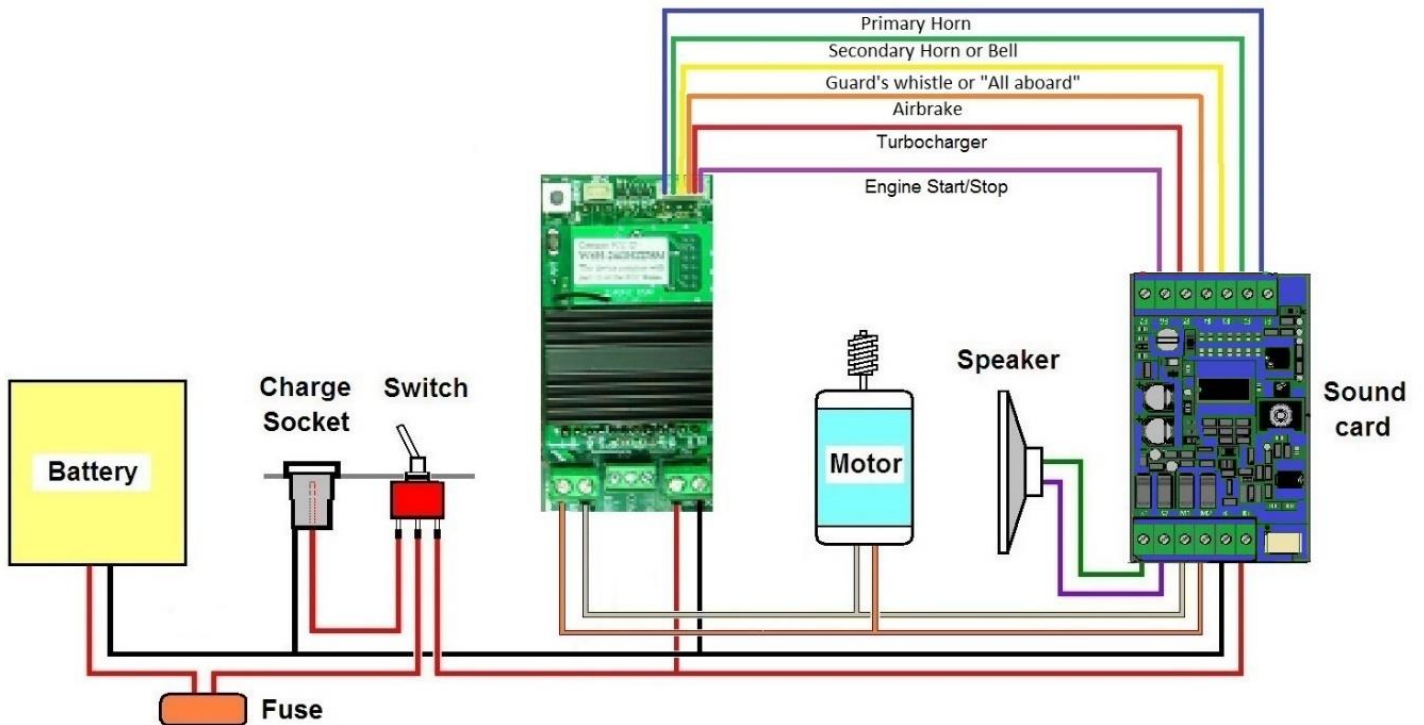

To connect the Crest Revolution, the adaptor plug for custom installations is used with the outer red, orange, grey and black wires being connected as shown. All auxiliary functions should be set to momentary by selecting MENU – ASSIGN FUNCTIONS – AUX FUNC SETUP. However, the bell, if in use, can be set to latch.

Note also that early Revolution receivers, without the onboard sound, will start the soundcard immediately when power is switched on. However, this will not happen with later Revolution receivers with the onboard sound. With the later ones you will need to throttle up three button presses to switch on the sound which will then stay on.

6. THE INFRA-RED RECEIVERS

The infra-red receivers accept commands from the handheld remote control to adjust or trigger sounds. Two receivers are provided. One is fixed in the middle of the soundcard. The other is on a flying lead which plugs into the small white socket as shown on page one.

In some installations, the soundcard is visible when installed in the loco. This usually occurs when the soundcard is mounted on the floor of a cab, with or without windows. In this case, the remote control can be pointed directly at the soundcard and the on-board receiver is all that is needed.

If the soundcard is within the loco and is not visible then the flying lead needs to be used. Plug it into the white socket and glue the black receiver, round side outwards, to any external surface of the loco to which you can easily point the radio control. Do not paint the receiver. When the soundcard is on the floor of the vehicle then a common practice is to drill a hole in the floor and glue the black receiver to the underside. You can then operate the TV remote by pointing it under the vehicle so that the IR signal bounces up off the sleepers and ballast.



7. THE REMOTE CONTROL

The soundcard will operate with any Sony™ TV remote control using the buttons described in this section. It will also operate with any universal remote control when it is set to Sony coding. You will probably find a number of codes listed for Sony and will need to try each one until you get to the code which operates the soundcard volume, mute and function buttons correctly.

Please ensure that your remote control has batteries installed and follow the instructions which come with it to set the coding. For the Brightstar, hold down the Setup button until the LED comes on and then enter 605. The LED will go off and it is ready for use.



Note that the buttons on the remote control auto-repeat if held down. If you want a single event to occur, like turning on the safety valve, then press the safety valve and release it immediately. If you want to make

a large change in volume or tone then you can hold the button down to avoid the need to press the button repeatedly.

The **Mute** button will start and stop the sound and lets you select the different sounds. The **ENTER** button changes the way the sounds operate.

8. CONFIGURING THE SOUND CARD

The soundcard has three modes:

1. **Sound setting** mode in which you can select the sounds you want by pressing the Mute button.
2. **Operating setting** in which you can choose the way the sounds are triggered by pressing the Enter button.
3. Run mode in which the soundcard does its job on your railway.

All sound settings are done using the TV remote control and we will cover that first. To place the soundcard into Sound Setting mode point the remote control at the soundcard or the receiver on the end of the flying lead and press the **Mute** button. The LED on the soundcard will blink slowly and all sounds will cease. Next press one of the keys on the remote control and the number of beeps will indicate the current sound setting as listed below. Press the key again and the setting will move to the next sound listed below. At any time, you can press the **Mute** button to hear the sound you have selected or to return to run mode.

All operating settings are also done using the TV remote control. To place the soundcard into Operating Setting mode point the remote control at the soundcard or the receiver on the end of the flying lead and press the **Enter** button. The LED on the soundcard will blink fast and all sounds will cease. Next press one of the keys on the remote control to indicate the current operating mode and again to move through the

Note: Some TV remotes do not have an **Enter** button or they have an **Enter** button which the soundcard is unable to understand. If you hit this problem then you can get into Operating Settings by doing the following:

- Press **Mute** to get into Sound Setting. The LED will blink slowly.
- Press the Zero button.
- You will now be in Operating Setting. The LED will blink fast.
- When you are done, press **Mute** to return to Sound Setting.
- Press **Mute** again to return to run mode.

options listed below. At any time, you can press the **Enter** button to return to run mode.

The volume of all sounds can be varied by using the volume up/down buttons on the TV remote while that sound is playing.

All settings are listed in a quick reference table on the last page of these instructions.

9. SOUND SETTING OPTIONS (MUTE BUTTON)

Power Button – Not used in sound setting.

Button 0 – Not used in sound setting.

Button 1 – Horn. This is used to select the style of horn which suits your locomotive. Every one of these horns has an adjustable pitch and volume. Each time you press the 1 button the number of beeps will increase to indicate that the horn listed below has been selected. If you wish to hear that horn, press the Mute button on the remote control and then button 1 to start the horn and then again to stop it. While the horn is sounding, you can use the volume buttons to vary the volume. The pre-selected horns available are:

Beeps	Horn
1	Amtrak K5LA (Default)
2	Leslie A200 Tyfon
3	Nathan K3LA
4	Wabco E2
5	Nathan M5
6	Leslie S-3L

Button 2 – Bell. This is used to select the type of bell from the list below.

- 1 **beep** – Bronze bell **(Default)**
- 2 **beeps** – Steel bell
- 3 **beeps** – Electronic bell

Button 3 – Guard. This is used to select the guard's sounds from the list below.

- 1 **beep** – Sounds "All aboard". **(Default)**

Button 4 – Not used in sound setting.

Button 5 – Turbo sound. If a turbocharger has been selected then this button can be used to select the pitch.

- 1 **beep** – Low
- 2 **beeps** – Mid **(Default)**
- 3 **beeps** – High

See section 12 to change the turbo volume and pitch.

Button 8 – Engine Sound. You can choose from the following:

- 1 **beep** – EMD 16-567B for EMD F7, F3 and E8 locomotives
- 2 **beeps** – EMD 16-645 for EMD SD-40 and GP-40 locomotives **(Default)**
- 3 **beeps** – EMD 16-710 for the SD-70 locomotive
- 4 **beeps** – ALCO 244 for Alco PA, FA-1, RS-2 and RS-3 locomotives
- 5 **beeps** – GE 7FDL 16 for GE P42 Genesis, Dash 9 and U25-B locomotives

See section 11 to change the engine rev range.

10. OPERATING SETTING OPTIONS (ENTER BUTTON)

Power Button – Battery or Track Power. The soundcard can be used with battery power, with or without a locomotive, or with locomotives which are powered from the track. Press this button to switch:

1 beep – Battery power. **(Default)**

2 beeps – Track power with a 9v support battery. The soundcard will automatically turn itself off when the locomotive has not moved for thirty seconds. Turning the power up a little will turn the soundcard back on. The support battery will automatically recharge when the track voltage exceeds 10v.

3 beeps – Track power with a 7.2v support battery. The soundcard will automatically turn itself off when the locomotive has not moved for thirty seconds. Turning the power up a little will turn the soundcard back on. The support battery will automatically recharge when the track voltage exceeds 8v.

Button 0 – Not used

Button 1 – Whistle operation options. There are three whistle operating modes available:

1 beep – Indicates manual operation. In this mode all sounds are triggered by manual press of the TV remote button or by Function 1. With battery radio control, the whistle will sound for as long as function 1 is closed. With track power the whistle will sound for one second when function 1 is triggered by track magnets. **(Default)**

2 beeps – Indicate simple automatic mode. This is designed for controllers which have no function buttons, as is often the case with track power, or at exhibitions, etc. where you don't want to operate manually. The whistle will sound once automatically when the loco moves off and then once more three times a minute when the loco is on motion. A reed switch can be placed under the loco and be connected to the F1 terminal to make the whistle sound when the loco passes over a magnet. Another reed switch, connected to the F2 terminal, can be used to trigger the bell. If the bell is set to one beep then it will ring continuously until the loco passes over another magnet. If the bell is set to two beeps then it will ring for the set time.

3 beeps – Indicate American automatic mode. Again this is designed for controllers which have no function buttons, as is often the case with track power, or at exhibitions, etc. where you don't want to operate manually. However, it follows American rules. The whistle will sound two long toots when the loco moves off forwards or three short when backing up. If these occur the wrong way around then reverse the leads at the M1/M2 terminals. When the loco stops, a single short toot will indicate brakes on. A reed switch can be placed under the loco and be connected to the F1 terminal to make the whistle sound the grade crossing sequence when the loco passes over a magnet. Another reed switch, connected to the F2 terminal, can be used to trigger the bell. If the bell is set to one beep then it will ring until the loco passes over another magnet. If the bell is set to two beeps then it will ring for the set time.

Button 2 – Bell operations. This is used to select the bell operation from the list below.

- 1 beep** – Manual bell. Starts ringing repeatedly when the button is pressed until the button is pressed again.
- 2 beeps** – Timed bell. When F2 is triggered, rings repeatedly for a predetermined time. To set that time, press the Mute button to exit setting mode and then press Button 2 to ring the bell. When the bell has rung for as long as you want, press Button 2 again to stop the ringing. The time is then set and the bell will ring for that time when F2 is triggered while running.
- 3 beeps** – Automatic bell. Rings repeatedly when the motor voltage is less than 4 volts. **(Default)**
- 4 beeps** – Automatic bell. Rings repeatedly when the motor voltage is less than 8 volts.
- 5 beeps** – Automatic bell. Rings repeatedly when the motor voltage is less than 12 volts.
- 6 beeps** – Manual bell. Rings once only each time the button is pressed.

Button 3 – Conductor. “All aboard” sounds each time the TV remote button 3 or function 3 is triggered.

Button 4 – Brakes. This gives you three braking options:

- 1 beep** – No braking sounds required. **(Default)**
- 2 beeps** – Automatic brake squeal whenever the locomotive comes to a halt.
- 3 beeps** – Automatic airbrake release when moving off.
- 4 beeps** – Automatic brake squeal whenever the locomotive comes to a halt plus automatic airbrake release when moving off.

Button 5 – Turbocharger and Exhaust. These can be switched on or off by:

- 1 beep** – Turbocharger and exhaust reverberation not required. **(Default)**
- 2 beeps** – Turbocharger sounds automatically according to the locomotive motion.
- 3 beeps** – Exhaust reverberation when accelerating.

Button 6 – Engine starting and stopping

- 1 beep** – Manual. Pressing the button 6 or F6 is triggered will shut down and start up the engine using the starter motor **(Default)**
- 2 beeps** – Automatic. The engine will shut down after one minute of no movement and will start up again, using the starter motor, when the throttle is given a slight nudge up then back. Once the engine has started you can then throttle up and move off. This option gives you the ability to start the engine when no transmitter function button is available.
- 3 beeps** – Manual. At power up the engine will not start automatically but an airbrake release will be heard to confirm that the soundcard is working. Pressing the button 6 will then start up and shut down the engine using the starter motor.

Button 7 – Engine Sensitivity. The soundcard is programmed to make the engine loud when accelerating and softer when coasting and slowing down. The power button changes the level of sensitivity as indicated by the number of beeps when pressed. One beep indicates maximum sensitivity. Five beeps sets minimum sensitivity ie. the engine will be loud all the time. The **default** sensitivity is two but change it to one if you want more sensitivity or three or more if the chuff sounds erratic. We recommend one beep for pushbutton throttles.

Button 8 – Engine Type. This will operate in three ways:

- 1 beep – Manual notch up with no gear change. Revs increase proportionally to the speed. (**Default**)
- 2 beeps –Automatically revs up to notch 5 to move off with engine revs twice tickover.
- 3 beeps – Automatically revs up to notch 8 to move off with revs three times tickover.

It is important to tell the soundcard when your loco starts moving and hence when to start revving up. Do this by slowly increasing the throttle until the loco is just about to start to move. Then press the power button on the remote control. This tells the soundcard the voltage at move off.

11. SETTING THE ENGINE REVS

This is a once only exercise although you can repeat it later if you want to make a change.

First press Mute to stop the sound and go into programming mode. Then use buttons 5, 6 and 8 to set your chosen engine as described in the previous section.

The last step then is to set the rev rates when static and when in motion. Press Mute to come out of programming mode so that you can hear the sounds. Then do the following:

1. Use the channel up/down buttons to adjust the tickover revs to the desired rate.
2. Turn up the locomotive throttle until you get to the point where you want the revs to increase. Then press the Power button on the remote control. Most people press the Power button at a very small amount of throttle movement so that the engine revs increase well before the locomotive starts moving.
3. If the engine type (Button 8 above) is set to 2 or 3 beeps then you need to do no more. The locomotive is ready to run.
4. If the engine type (Button 8 above) is set to 1 beep then the revs will increase as the locomotive speed increases. With the engine in motion, you can increase or decrease the rate at which the revs change by using the channel up/down buttons.

12. SETTING THE TURBOCHARGER

This is also a once only exercise although you can repeat it later if you want to make a change. First select the turbocharger by setting mode button 5 to 2 beeps. You can change both its pitch and the volume. With the engine running on idle, press the F5 button on the TV remote. The engine sound will disappear leaving just the turbo. You can then use the channel up/down buttons to vary the pitch and the volume up/down buttons to vary the volume. Press the F5 button again to restart the engine sound again so that you can hear them together. In sound settings, button 5 will make large changes to the pitch.

13. RESETTING THE SOUND CARD TO THE FACTORY DEFAULTS

Being able to vary so many settings, you may get into a tangle where the sounds you are hearing don't make sense. In that case, go into run mode (so that the sounds are not muted) and holding down the 0 button on the remote control until you hear five beeps. This will cause the soundcard to reset itself back to its factory defaults. It will not change the country setting.

14. OPERATING THE SOUND CARD

When the loco is running, the engine sounds should operate automatically, getting louder when accelerating and softer when slowing down or idle.

Where your controller has function buttons then you can use them to trigger terminals F1 to F6 as follows:

- Trigger 1. Sounds the main horn. On track power the horn will sound for one second so that it can be triggered by track magnets. On battery power the horn sounds for as long as the function is triggered.
- Trigger 2. Operates the bell or the two tone horn 7.
- Trigger 3. Sounds "All aboard" and/or the conductor/guard's whistle.
- Trigger 4. Sounds the airbrake release.
- Trigger 6. Starts and stops the engine.

15. TROUBLE SHOOTING GUIDE

THE REMOTE CONTROL WON'T WORK

Start the soundcard, press any button on the remote control and the LED should flash. If it does not flash then the battery probably needs replacing. If the battery is okay then try stretching the battery contact springs and then replace the battery.

If the LED flashes but the soundcard does not respond then the Sony™ coding may have been lost and can be reset as follows. Refer to the remote control's instructions for resetting the Sony coding. You will probably find a number of codes listed for Sony and will need to try each one until you get to the code which operates the soundcard volume, mute and function buttons correctly. For the Brightstar, hold down the Setup button until the LED comes on and then enter 605. The LED will go off and it is ready for use.

If the remote control still does nothing then the problem may be the infra-red receiver on the loco which must not be painted or obstructed.

I GET NO SOUND AT LOW SPEEDS WHEN USING TRACKPOWER

On trackpower, you may get no sound at low speeds until the track voltage gets up to about nine volts. This indicates that the support battery is flat. Charge the battery by running the loco for ten minutes with the track voltage at least one volt more than the nominal battery voltage.

I GET NO SOUND AT ALL

Press the Mute button on the remote control in case the sound has been accidentally turned off.

Switch the loco off and then on again. When the soundcard starts, the LED should flash once. If not then use a multimeter to check that there is at least nine volts at the B+ and B- terminals and the M1/M2 voltage is greater than zero to wake up the soundcard. If not then check your wiring in case something has come adrift.

Check that the speaker is connected correctly.

If you are bench testing and there is a light shining on circuit board then this can put the soundcard into factory programming mode and stop the sound. In that case, the yellow LED next to the F1 terminal will stay on. You can fix this by covering the IR receiver on the soundcard and on the flying lead, if fitted.

THE SOUND CARD MAKES A CLICKING NOISE OR SHUTS DOWN

This most often occurs when the horn is sounded. It is caused by the soundcard restarting because there is insufficient voltage in the track or the battery to sustain the volume setting. Recharge the battery.

WHEN INSTALLED IN A LOCO, THE SOUND STOPS INTERMITTENTLY AND I HAVE TO RESET THE CONTROLLER TO GET IT GOING AGAIN

The soundcard maximum output is 2 amps. If this is exceeded as a result of a short circuit, a heavy load and/or high volume settings then the soundcard will shut down. Also, if the soundcard is installed in a very confined space and is run for a prolonged period at high power then it can overheat and switch itself off while it cools down.

HOW TO RESET YOUR SOUND CARD

A time may come when you have been adjusting the sound and you want to start again. This can be achieved by resetting the soundcard back to the settings when it left the factory. You can do this by pressing the 0 button on the remote control and hold it down for three seconds. The soundcard will beep five times when the reset is complete.

16. USING AN EXTERNAL AMPLIFIER FOR RIDE ON RAILWAY LOCOMOTIVES

When used in 5 inch and 7¼ inch ride on railways there is a lot of environmental noise. The output of the soundcard alone is not sufficient for these environments and an external amplifier needs to be used. The wiring diagram overleaf shows how the soundcard can be interfaced to a commercial stereo amplifier in a loco with 24v motors powered by two 12 V batt

Note that the soundcard can handle a max DC. A battery which is labelled as 24 volts v output 28 volts when fully charged and will damage the soundcard if connected direct resistors on the M1/M2 terminals keep the to 24v.

A 2x15 watt stereo amplifier is suitable. It may require the 100Ω resistor to be changed if the output volume is too low then raise the value of the 100Ω resistor.

A single speaker can be used on the right output or two speakers on the left and right outputs.

Any of the five functions can be used by means of a pushbutton between the function terminal and ground. The sound functions available are horn, bell, "All aboard", airbrake release and engine start/stop. Only the horn wiring is shown in the diagram. The installation can be made more robust by enclosing the soundcard, capacitor and two resistors into a plastic project box as shown in the diagram.

The whole can then be fixed to the top of the amplifier using silicon. Select a speaker which matches the impedance and power output of the amplifier. It is also important to make a soundbox which is an airtight fit to the back of the speaker. This will improve both volume and sound quality.

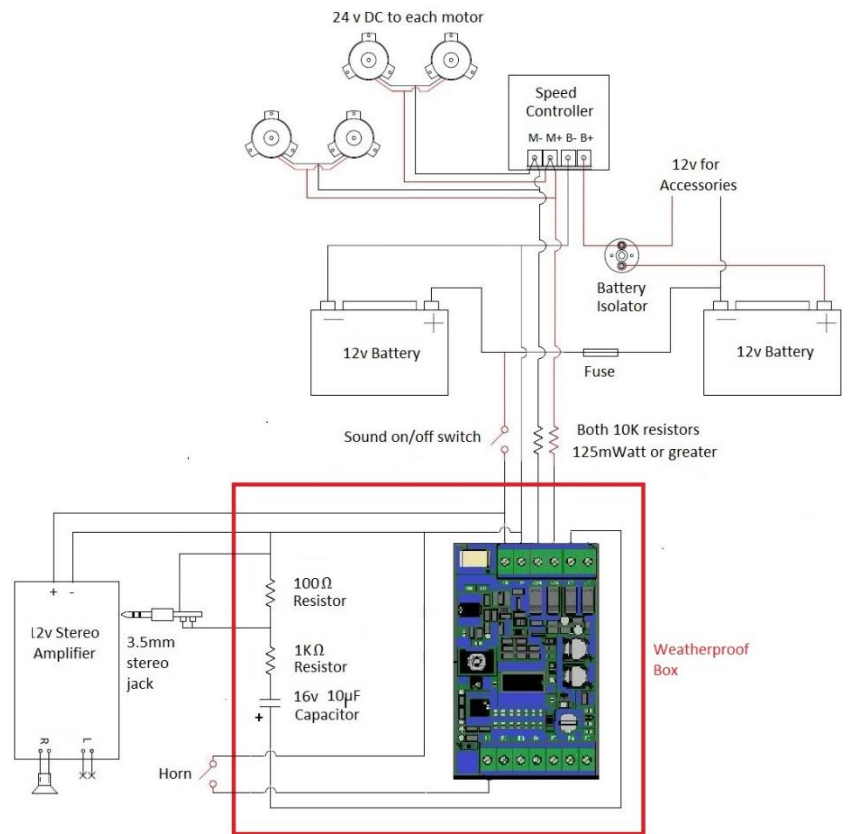

Premium American Diesel Instructions - US. 15 June 2023 Version 22

For more information, please visit the web site at www.mylocosound.com or e-mail sales@mylocosound.com.

Copyright © 2013-23 MyLocoSound Pty. Ltd.

TV Remote Control	Beeps	Mute Pressed - Sound Setting	Enter Pressed - Operating Setting
Power Button	1		Locomotive is battery powered
	2		Locomotive is track powered with 9v battery
	3		Locomotive is track powered with 7.2v battery
Button 1 - Horn	1	Amtrak K5LA	Manual horn control
	2	Leslie A200 Tyfon	Automatic horn every 20 secs
	3	Nathan K3LA	US horn rules with grade crossing
	4	Wabco E2	
	5	Nathan M5	
	6	Leslie S-3L	
Button 2 - Bell	1	Bronze bell	Manual on/off
	2	Steel bell	Automatic timed ring when F2 is triggered.
	3	Electronic bell	Rings when motor below 4 volts
	4		Rings when motor below 8 volts
	5		Rings when motor below 12 volts
	6		Rings once each time button is pressed
	7		Bell replaced with European two tone horn
Button 3 - Guard	1	"All aboard"	Manual
Button 4 – Brakes	1		No brake sounds required
	2		Automatic brake squeal as the loco stops
	3		Automatic airbrake release when starting
	4		Both brake sounds
Button 5 – Turbo	1	Low turbo pitch	No turbo or exhaust reverberation
	2	Medium turbo pitch	Automatic turbo
	3	High turbo pitch	Automatic exhaust reverberation
Button 6 – Engine start/stop	1		Automatic start then manual start/stop
	2		Start/stop using throttle
	3		Manual start/stop
Button 7 – Engine Sensitivity	1		Maximum sensitivity to throttle changes
	to		∨ ∨ ∨
	5		Minimum sensitivity to throttle changes
Button 8 – Engine Type	1	EMD 16-567B	Revs increase with speed
	2	EMD 16-645	Move off on notch 5
	3	EMD 16-710	Move off on notch 8
	4	ALCO 244	
	5	GE 7FDL 16	