

TrackSide 7

R/C

2.4GHz R/C

for Large Scale

Track Powered Trains

Operation and Installation Manual

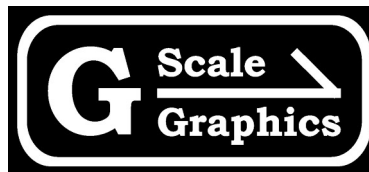

G-Scale Graphics
5860 Crooked Stick Dr.
Windsor, CO 80550
970-581-3567

GScaleGraphics@comcast.net
www.GScaleGraphics.net

Contents

	Page
Overview	3
The Radio System	4
The TrackSide R/C Control Board	4
Installation	5
Automated Station Stops	6
Manual Operation	7
Interactive Display Operation	8
The Wireless Option	8
Transmitter Command Summary	9
Trouble Shooting	11
User Programming	12
Two Track Operation	14
Adding Wireless Reed Switch	14
Specifications	15
Meanwell Power Supplies	16

Overview

Trackside 7 R/C (Radio Control)

is an electronic speed control designed for remote control of track powered large scale trains. The pocket sized transmitter allows you to control and follow your trains anywhere, without being tied down to a “control panel”.

Automated station stops and/or back 'n forth trolley mode can be implemented using our track mounted reed switches and a magnet on the loco.

This new 7th generation also includes features for train display operations; automatic or interactive. Visitor presses a button to run the train for X minutes. Or, the train runs automatically every X minutes.

A regulated DC power supply (e.g. 24V, 5-10A) must be used to supply power to the Trackside R/C unit, which then throttles the PWM (Pulse Width Modulated) voltage to the track via radio control.

The pocket sized TX (Transmitter) controls the Trackside base station via 2.4GHZ DSSS radio signals.

- No modifications to locomotives required
- Pocket sized transmitter
- Precise speed control
- Up to 10 amps of track power
- User programmable
- Control one or two loops of track from the same transmitter

The Trackside base station can pass up to 10 amps of current from the power supply to your track. That is more than enough to handle one or more locomotives pulling a full train. Typical current draw for one locomotive motor is around 1-2 Amps.

User programmable options give you control over operating parameters, without the need for a computer.

- 1) NOT for use with older unregulated power packs like PH Hobbies and MRC 6200. Many low cost train “Power Packs” do not have regulated DC outputs. Their outputs contain a high content of AC voltage that may damage the Trackside R/C unit. Bridgewater and Crest Switching power supplies are fine. If in doubt, please call us.
- 2) Locomotives containing DCC decoders that also allow operation on regular DC voltage may not operate properly with the Trackside R/C. Our PWM output signal makes some DCC boards think they are in DCC mode. In that case, you can install our PWM to DC Converter between the TrackSide R/C and the track.
- 3) PWM may also affect the lighting circuits of some locomotives. Again, if that is a problem for your setup, we recommend installing our PWM to Linear DC Converter on the output of the TrackSide R/C.

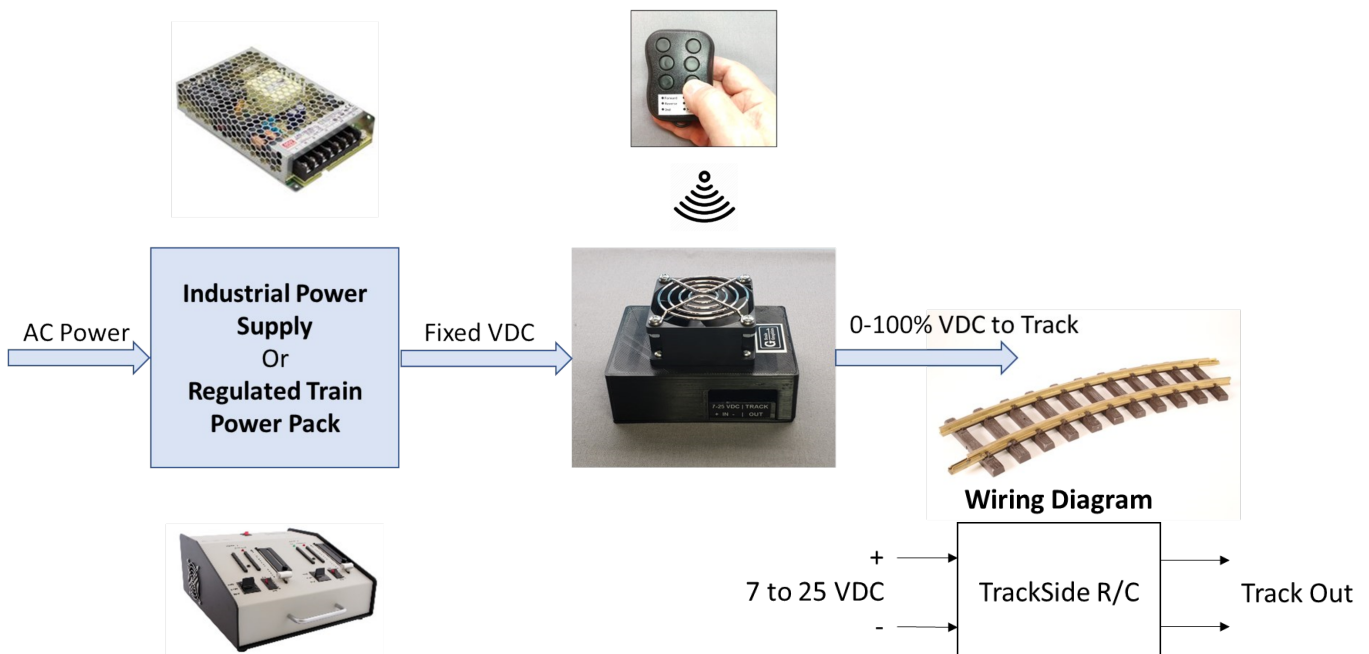

The Radio System

The **TrackSide R/C** uses a new high-tech 2.4GHZ system designed for industrial use. The range is excellent, up to 800 ft. Best reception will be obtained with line-of-sight between the TrackSide base station and the TX, but most obstacles are not a problem. Raising the base unit above ground level may improve reception, if needed.

Each Trackside base station “learns” its transmitter and will only respond to that transmitter and no others. Multiple **TrackSide R/C** systems can be used in the same location to run multiple loops of track, without interference. There are no channels or frequency selections to worry about.

The 6-button handheld transmitter uses two long lasting replaceable AAAA batteries. There is no on/off switch. It is always ready to use, and only transmits while a button is pressed. Keep the transmitter in your pocket or attached to a neck lanyard.



One transmitter can control two base units, and therefore two separate loops of track.

The TrackSide R/C Control Board

The **TrackSide base station** houses a circuit board, which is a combination control board and radio transceiver. Transmitter commands control a powerful (and silent) PWM (pulse width modulation) motor driver designed to allow nice slow prototypical speed control of your locomotive. Adding momentum to the throttle enhances the prototypical operation. Momentum is fully programmable, and can be turned on and off via the transmitter to assist with switching operations. (Toggle Rate)

TrackSide R/C operates over a wide range of DC input voltage (7-25V). The power input is protected from damage due to reverse polarity, it just won't operate until the polarity is correct. The output circuitry is protected from short circuits via an easily accessible fuse.

A DIP switch, push-button and LED provide simple user programming without the need for a computer.

The integrated 2.4GHZ radio receiver and antenna provide excellent operating range.

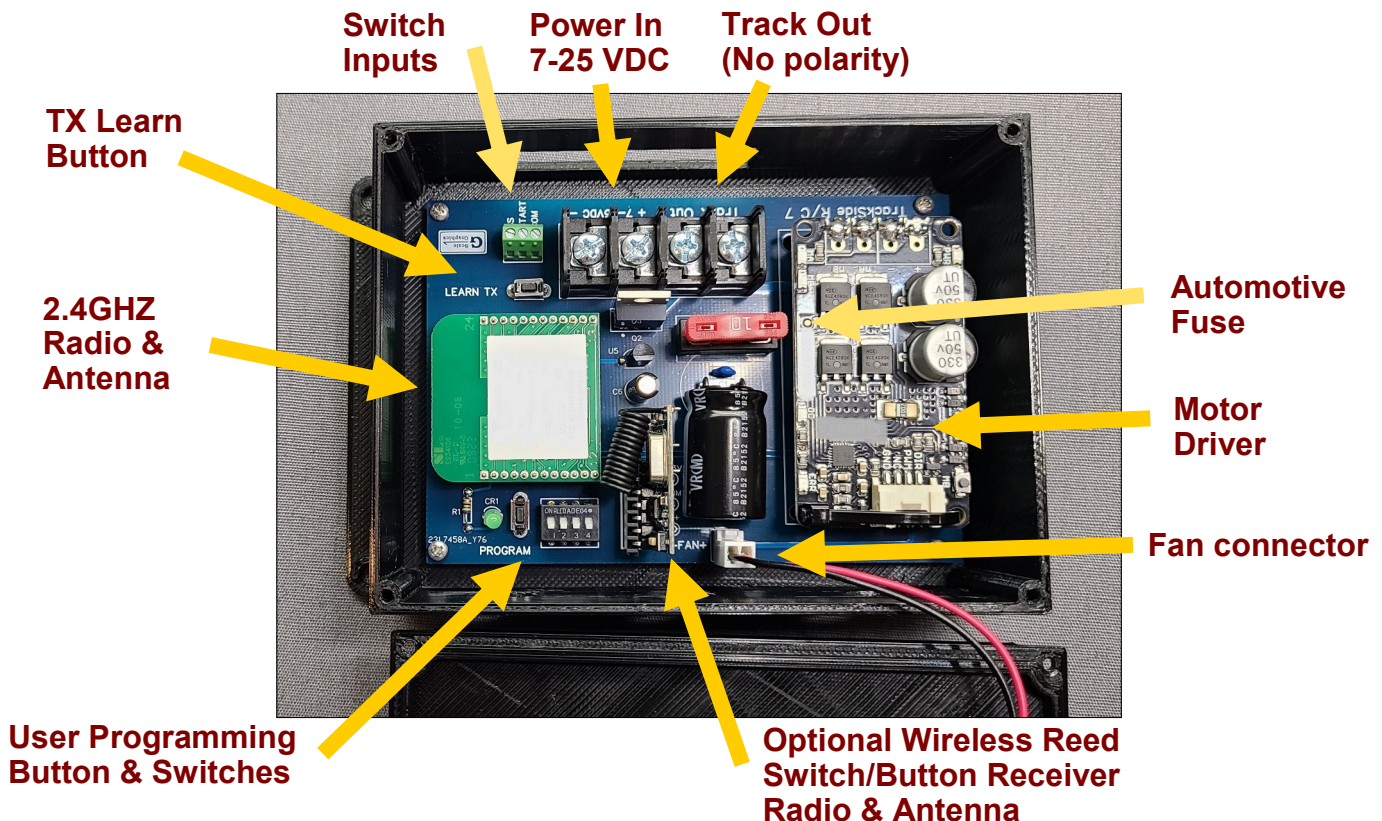

Installation

The **TrackSide base station** can be mounted anywhere between the power supply and the track. All wiring from power supply to **TrackSide base station**, and **TrackSide base station** to track, should be as short as possible to minimize voltage drops. For long runs, wire gauge should be at least 16 gauge or better. 12 gauge Landscape wiring works well.

Remove the cover/fan assembly via the 4 corner screws to access the wiring terminals.

Power and Track connections to the **TrackSide base station** are best made using crimped terminal lugs, but tinned wire can also be used. The switch inputs (COM, Start, SS) uses screw terminals that accept small gauge tinned wire.

Power Input

Connect 7 to 25 VDC. Reverse polarity will not cause damage, but the control will not operate. The **TrackSide base station** will not function below 7vdc input. When proper power is supplied with the correct polarity, the green LED inside the box will be ON, but only visible with the cover off.

Warning! Most train "Power Packs" with a knob on them (e.g. the MRC 6200) are very poor power sources. Their "DC" output is unregulated and unfiltered. The large AC component of their output may cause damage to the Trackside R/C electronics. If you can measure more than 1 volt AC on the "DC" output of your power pack, it is not suitable!

It is assumed that power to the system will be switched on/off at the power supply.

Any DC power supply with a regulated output between 7 and 25 VDC will work. Bridgewater and Crest Switching power supplies are fine. The greater the voltage, the faster your top speed will be. There is nothing special about power supplies made specifically for trains, other than they may have some built-in meters. Industrial power supplies are much better, lower cost, and smaller.

Some common fixed output train supplies:

Crest (Aristo-Craft), Elite Dual, 22V/13.8V, 13A/20A, CRE55465, \$206

Crest (Aristo-Craft), Elite Single, 24V, 15A, CRE55468, \$242

Aristo-Craft, Ultima, 18-21V, 10A, ART-5460, **obsolete, not suitable.**

Industrial Switching Power Supplies:

Meanwell, 24V, 6.5A, LRS-150-24 (our recommendation for most applications.)

Meanwell, 24V, 8.8A, LRS-200-24

Meanwell, 24V, 14.6A, LRS-350-24

and many other models by Meanwell, many under \$50.

Available from TRCElectronics.com

Must supply your own AC cord/connection to the terminal block.

Track Output

A maximum of 10 amps is available from the board. An ATC automotive fuse is located under the cover of the box. If you have a derailment or other catastrophe causing a short on your track, it is highly likely that this fuse will blow. We may ship with a 5 amp fuse installed. You may increase this to 7.5A, or 10A as needed if you blow fuses during normal operation; i.e. not due to a derailment or direct short. Keeping the fuse size small provides the best protection for the control.

At power up, if the train doesn't run in the direction you usually run in, just swap the track output wires. At power-up, the train will be ready to run forward without having to change direction on the TX.

Transmitter / Receiver Setup

There are no channels or frequencies to worry about. The receiver "Learns" the transmitter and will respond to no others. **Your receiver has already learned the transmitter it shipped with at the factory.** So no setup should be required.

In the event you need to re-learn your TX, you will need to remove the cover on the **TrackSide base station**. To re-learn, press the **Learn** button on the **TrackSide R/C** board. The LED will start blinking. Press and hold the



**Meanwell
Industrial Power Supply
LRS-150-24**

Stop key on the transmitter until the LED stops blinking. They are now linked together.

The transmitter batteries are accessible by removing the 3 screws on the back. Pressing any key on the transmitter should cause the **TrackSide base station** LED to blink off. If it doesn't, check the transmitter batteries. The batteries are accessible by removing the 3 screws on the back of the transmitter.

Automated Station Stops

An automated station stop slows down the train, waits at the station for a predetermined time, then accelerates back to its original running speed. Station stops add interest to your open house or public displays.

Automated operation is easily achieved with the TrackSide R/C. You just need to add a track mounted reed switch to your track, and a magnet on the bottom of your locomotive.

Automated station stops are initiated by a track mounted reed switch placed ahead of the station. The reed switch initiates deceleration to a stop. You can make as many stops as you like, one reed switch per station. The distance from the reed switch to the stop depends on the speed of the loco, and the station stop decel rate set in user parameter 1. Once you have established the desired setup, save the loco speed. Then recall the speed from the transmitter at the beginning of your operation session to insure your loco stops at the proper location.

Any number of hardwired reed switches can be connected in parallel to terminals SS, COM on the trackside. However, you may not want to run long lengths of wiring around your layout. Wireless Reed Switches eliminate the long wire runs. They can be powered locally from the track or a 9V battery

When running in back 'n forth trolley mode (Parameter 3—Option 1), with intermediate station stops, two reed switches are used at each end of the track. Single reed switches are used for the intermediate stops.

Automated reversing is accomplished using a second reed switch placed about 6" after the decel magnet. This second trigger will cause the loco to depart the station in the opposite direction. Reed switch spacing requirements vary with speed of the loco. 12" or greater is a good starting point. As long as the second reed switch is crossed prior to coming to a full stop, it should work. *Caution: Provide end of track bumpers or wheels chocks, just in case.*

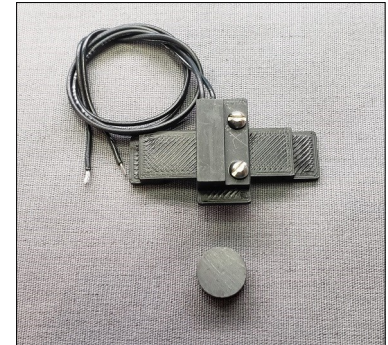

Hardwired Track Reed Switch (to SS, COM) and Loco Magnet



Wireless Reed Switch talks to receiver in TrackSide

Wireless Reed Switch Connected to track power

When running in back 'n forth trolley mode and no intermediate station stops (Parameter 3—Option 6), only one reed switch is required at each end of the track.

The distance the reed switch is located from the station will depend on your running speed. Some trial and error will be required to find the proper location and/or speed. You can then save this speed using 2nd key, and Slow key.

Manual Operation

Power-Up

At power-up, the locomotive will be stopped, ready to proceed forward. Momentum is off (fast rate).

Setting Direction

Press Forward or Reverse as desired to change direction while the locomotive is stopped (will not function while in motion).

Setting Speed

The Faster and Slower buttons will change the speed setting. Momentary presses for small speed changes, or hold the button down to ramp speed up or down. Min and Max Speed settings are set in Throttle Programming mode. The default settings are Min Speed = 0% power supply voltage, and Max Speed = 100% power supply voltage.

Save Running Speed

Set the speed of your loco to your normal running speed. To save it, press the 2nd, then Slower button. Now any time you want to recall that speed, including from a dead stop, just press the 2nd, then Faster button. The loco will accelerate (or decelerate) at the current momentum rate.

Momentum/Fast Rate

"Momentum" is a delayed response to a change in speed setting. This simulates the slow response of a heavy train. Toggle the rate from fast to momentum, and vice versa, by pressing "2nd, Stop". Use the fast rate for a quicker response during switching moves. Momentum refers to the user programmed throttle momentum set by parameter 4 (see User Programming). Fast rate is selected by default at power up.

Emergency Stops

Pressing the Stop button while running will make a quick stop, but not instantaneous. This avoids gear damage due to the real momentum of the train.

Throttle Programming Min and Max speeds

You can program the min and max throttle speeds (voltage). Most motors require several volts to get moving, so if you set the min speed just slightly less than what it takes to make the loco move, you will eliminate the delay in getting the loco moving. (Note: All locos have different min speeds, so this may only be useful when always running the same loco. Max speed setting is useful for setting a safe maximum speed to avoid derailments when children are operating the loco.)

To enter throttle programming mode, hold the **2nd key, Slower, and Stop buttons** down until the LED in the **TrackSide base station** starts flashing at a fast rate. You will now have full speed control from 0 to 100% power supply voltage.

To set min speed, use the Faster button to just barely get the loco moving. Then use the Slower button to just Stop it. Press **Reverse to set** the min speed (Speed must be less than 50% power supply voltage).

To set max speed, use the Faster and Slower buttons to run the loco at the desired speed. Press **Forward to set** the max speed setting (Speed must be greater than 50% power supply voltage).

To return to default throttle settings (min speed = 0% voltage, max speed = 100% voltage), press the 2nd key to save the default settings.

Press the **Stop button to save** the setting and exit throttle programming mode. LED will stop flashing. Note: Only one setting, either Min or Max can be set at one time. Exit to save, then re-enter for the second setting.

Two Track Operation

Two different tracks can be controlled by the same transmitter. The keys on the left side of the TX will control track 1, and the right side keys will control track 2. Each base unit must learn the same transmitter. Then using User Programming parameter 7, set up the track 1 base unit to operate in option 2, and the track 2 base unit to operate in option 3. Each base unit will respond at the throttle rate set by user parameter 4. Throttle programming, save/recall speed, and toggle rate, and interactive remote functions are all disabled in two track mode.

User Feedback

The standard black transmitter has a vibration motor in it which can be used for user feedback. (The Budget TX does not.) Pressing any button sends a radio signal to the base station receiver. The receiver (both TX and RX are actually transceivers, capable of bi-directional communication) will then return a signal to vibrate the transmit-

ter. This is useful to find dead spots in your layout or to check radio range. You will likely not want to use this all the time to save TX batteries. This function can be activated using User programming parameter 13.

Fuses

If you are blowing fuses due to derailments, or other causes of a short circuit, do not increase the size of the fuse. It is doing its job. If you continually blow fuses while simply trying to operate trains, then you can increase the fuse size from the 5 amps, to 7.5 amps, or a maximum of 10 amps. Running with the smallest size fuse that still allows you to operate will provide the best protection for the TrackSide R/C.

Interactive/Display Operation

Start Button

A hardwired Start Button connect to START and COM or a wireless Remote Start Button can be used to start the train running. It will ramp up to the saved running speed at a rate controlled by User Parameter 4. The train will then run for X minutes determined by User Parameter 6, and then slow to a stop, awaiting the next button press.

Interval Timer

In this mode, the train will start automatically, as if a start button were pressed, every X minutes as set in User Parameter 8. The timer is not a real time clock. It operates on elapsed time. The train will run at power up, and then start timing.

A display operator can intervene and take control at any time using the transmitter.

The Wireless Option

The wireless option includes a receiver that plugs into the TrackSide Base unit, a Wireless Track Reed Switch, a Magnet to mount on the locomotive, and a Wireless Start Button.

The wireless track reed switch contains a transmitter that is powered from the track. The wireless start button uses a CR2032 battery.



Trackside R/C Transmitter Commands Op Mode 1 (Single Track, Default)

Single Key Function

2nd Key function

Examples:

Press "Stop" key once to Stop.

Press the "2nd Key", followed by the "Stop" key to Toggle Rate.

Forward - Press momentarily to change direction to forward.
(see note below)

Reverse - Press momentarily to change direction to reverse.

Faster - Press momentarily to bump speed up. Hold down to ramp speed up.

Slower - Press momentarily to bump speed down. Hold down to ramp speed down.

Stop - Press momentarily or hold to perform a Quick Stop while running.

2nd - Press momentarily, followed by another key to perform the secondary function.

2nd, Forward - not assigned

2nd, Reverse - not assigned

2nd, Faster - Recall the saved running speed.

2nd, Slower - Save the current running speed.

2nd, Stop - Toggle the momentum rate; either fast for switching or slow per User Parameter 0 for prototypical speed changes.

Throttle Programming -

Enter Throttle Programming mode by holding down the **2nd, Slower, and Stop buttons** until the LED inside the Trackside base station starts flashing.

Use Faster/Slower Buttons to control speed (0 to 100%)

Press Forward to set the Max Speed (must be greater than 50%)

Press Reverse to set the Min Speed (must be less than 50%)

Press 2nd to reset throttle to full range (0 to 100%)

Press Stop button to exit and save changes at any time. LED will stop flashing.

Learn TX - Press the Learn button on the circuit board inside the Trackside box. LED will start flashing. Then press Stop on the transmitter. LED will stop flashing.

Note: Forward and Reverse won't function while loco is in motion. Direction of locomotive travel is relative to the way you place your loco on the track. Place your locomotive on the track in the direction it will normally travel. When the Trackside is first powered up, "Forward" will be selected. If your loco runs backwards, you can either reverse the wires to the track, or change User Parameter 5.

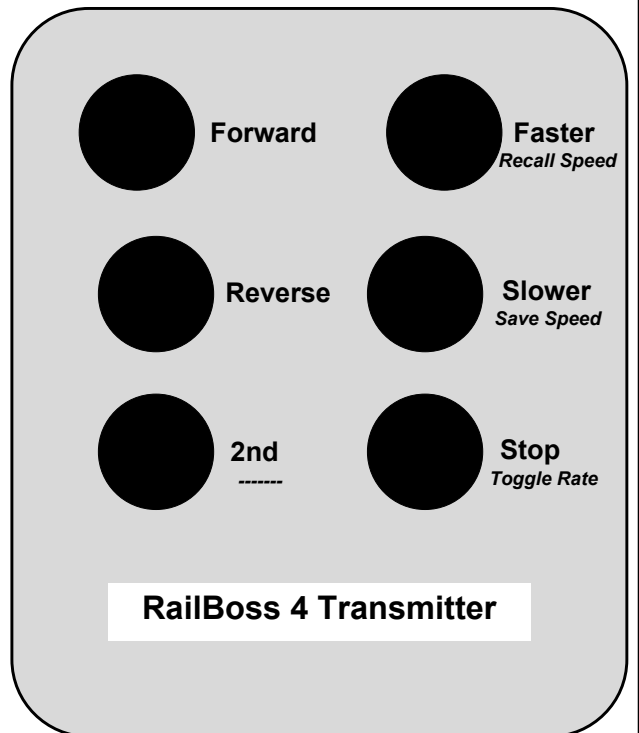

Trackside R/C Transmitter Commands Op Modes 2 and 3 (Two Track)

Single Key Function

2nd Key function

Examples:

Press "Stop" key once to Stop.

Press the "2nd Key", followed by the "Stop" key to Toggle Rate.

Faster - Press momentarily to bump speed up. Hold down to ramp speed up.

Slower - Press momentarily to bump speed down. Hold down to ramp speed down.

Stop - Press momentarily or hold to perform a Quick Stop while running.
Press while stopped to change direction.

Left side keys - Control the Base Unit that is programmed for Op Mode 2 and connected to track 1.

Right side keys - Control the Base Unit that is programmed for Op Mode 3 and connected to track 2.

Note: In two track mode, the throttle programming, save/recall speed, and toggle rate, and interactive remote functions are disabled. Speed will change at the User Programmed rate set in Parameter 0 of each base unit.

For two track operation from the same transmitter, both base units need to learn the same transmitter.

Learn TX - Press the Learn button on the circuit board inside the Trackside box. LED will start flashing. Then press Stop on the transmitter. LED will stop flashing.

Note: Direction change won't function while loco is in motion. Direction of locomotive travel is relative to the way you place your loco on the track. Place your locomotive on the track in the direction it will normally travel. When the Trackside is first powered up, "Forward" will be selected. If your loco runs backwards, you can either reverse the wires to the track, or change User Parameter 5.

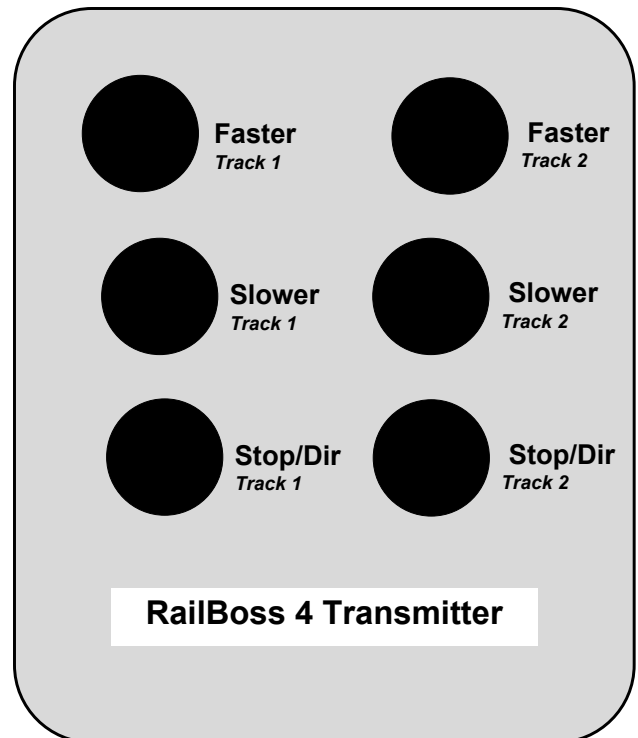

Trouble Shooting

- Nothing seems to be working ...

Check the power. The TrackSide LED should be ON. You should measure between 7 and 25 volts DC at the power input terminals. If the LED is OFF, your voltage is less than 7VDC or the polarity is backwards.

Check the fuse. If it is blowing during normal operation (not due to a short during derailment), you may increase the size from 5A to 7.5A, or 10A.

Pressing any button on the transmitter should cause the TrackSide LED to blink off. If not, check the transmitter batteries. Replace the batteries (AAAA's available on our website, if needed).

- The transmitter doesn't work at all.
Did the receiver successfully "Learn" the transmitter?
Open the transmitter case and make sure the batteries and green module are both fully seated.
Replace the batteries.
- The transmitter sometimes vibrates, and I don't have it programmed for that. Your batteries are low!
- Erratic throttle behavior? Reset throttle to default full range values using throttle programming procedure (See Throttle Programming).
- The loco doesn't start moving until I hold the Faster button for a long time.
The voltage is ramping from 0 volts to that required to move the loco. You can eliminate this dead time by programming the Min Speed setting to a higher value. (See Throttle Programming). However, this setting may be different for each loco.
- The loco starts moving as soon as I turn it on.
Program the Min Speed setting to a lower value.
- The locos runs in reverse at power up.
Reverse the wires at the track output.
- The loco won't run as fast as I like even though I keep trying to increase the speed setting ...
Maximum speed is determined by your power supply voltage or the Max Speed setting. You need more power supply voltage or you may need to restore the default throttle programming settings.
- I can't change direction with the loco stopped.
While the loco may be stopped, the track voltage still isn't close enough to zero volts to allow the direction change. Get into the habit of always pressing the Stop button to insure voltage goes to zero.
- If the lights in your loco are acting funny, not working well, or perhaps flickering, it may be due to the PWM (Pulse Width Modulation) output of the track throttle. It won't cause any harm to your loco, but it can be corrected, if desired, by using a PWM to Linear Converter available from us. This will provide a pure DC output to the track and loco.

Notes:

- 1) Many low cost train "Power Packs" do not have regulated DC outputs. Their outputs contain a high content of AC voltage that will damage the Trackside R/C unit. It may overheat and burn up the driver stage. If in doubt, please call us. The DC output of your power pack should measure less than 1 volt AC (measured on the AC scale of your meter).
- 2) Locomotives containing DCC decoders that also allow operation on regular DC voltage may not operate properly with the Trackside R/C. Our PWM output signal makes the DCC board think it is in DCC mode. Removing the DCC board and making direct connections between the track pickups and the locomotives motor (s) will solve this problem.

User Programming via the DIP Switch & Program Button

Some of the operating parameters of the **Trackside base station** can be modified to meet your individual needs. No programming is necessary to get your system up and running, only to modify it, if so desired.

User configurable parameters can be programmed using the 4-position DIP switch, the on-board push-button next to the DIP switch, and on-board LED. The DIP switch selects the parameter to be programmed, and the LED flashes the currently selected option.

Parameter 0

Station Stop Dwell Time

The elapsed time spent from a full stop at the station to departure.

Parameter 1

Station Stop Accel/Decel Time

The time it takes to decelerate to a full stop after crossing the station stop magnet. Use this adjustment not only to make the stop look prototypical, but also to match the characteristics of other locomotives making station stops using the same magnets. Thus, you don't have to move the magnets for each locomotive.

Parameter 3

Station Stops via Reed Switch

The reed switch at terminals SS and COM, initiates a station stop. This parameter allows you to control the percentage of time, that station stops occur;. e.g. at the 50% setting, after crossing the reed switch 10 times, the stop will occur an average of 5 times. The stops are random events, and thus very unpredictable, adding character, and a bit of mystery to your layout.

Note: When operating in point-to-point trolley mode, using the reversing magnets, you must have parameter 3 set for 100%. Otherwise, the loco will run off the end of the track, as the TrackSide will ignore the magnets X% of the time.

Parameter 4

Throttle Momentum

This parameter sets the amount of momentum applied to the throttle when the momentum function is turned ON using the "Toggle Rate" button. "Momentum" is the length of time it takes to accelerate or decelerate while holding down the Faster or Slower buttons.

Parameter 6

Run Time

Sets the number of minutes the train will run after a start has been initiated by either a start button or the interval timer.

Parameter 7

Operation Mode

One transmitter and two base units may be used to control two tracks.

Parameter 8

Start Interval Timer

Determines the elapsed time between automatic starts. Note: A remote start button press will reset this timer.

Parameter 13

User Feedback

Option 2 enables vibrate mode on transmitters equipped with a vibration motor. Upon pressing any key, the transmitter will vibrate if, and only if, the receiver actually received the signal. This can be used for testing radio range.

Enter Programming Mode

Hold the button (next to the DIP switch) down on the TrackSide board until the LED goes out. Release the button. The LED will begin flashing the option code of the selected parameter.

Select Parameter

Select the parameter you wish to view or program using the DIP switch. (the white square indicates position of the switch; e.g. for parameter 0, all switches are in the down or off position).

View Current Option Code

The LED will repeatedly flash the option code for the currently selected parameter; e.g. two flashes followed by a pause indicate option 2.

Change the Option Code

Momentarily press the push-button during the pause to advance the option to the next higher number, until you get the desired number of flashes.

Save the Option Code

During the pause between code flashes, press and hold down the push-button for about 4 seconds. Upon release, the LED should stay on solid. This saves the option code and exits User Programming. The new option will now be active.

Exit Programming Mode

To exit programming mode, hold down the Program button for 5 secs, then turn off TrackSide power.

To exit programming mode without saving any changes, just turn off TrackSide power.

Option	Parameter 0 - Station Stop Dwell Time	ON ▲ 1 2 3 4
1	10 secs	<input type="checkbox"/> <input type="checkbox"/> <input type="checkbox"/> <input type="checkbox"/>
2	20 secs	<input type="checkbox"/> <input type="checkbox"/> <input type="checkbox"/> <input type="checkbox"/>
3	30 secs	<input type="checkbox"/> <input type="checkbox"/> <input type="checkbox"/> <input type="checkbox"/>
4	40 secs	<input type="checkbox"/> <input type="checkbox"/> <input type="checkbox"/> <input type="checkbox"/>
5	50 secs	<input type="checkbox"/> <input type="checkbox"/> <input type="checkbox"/> <input type="checkbox"/>
6	60 secs	<input type="checkbox"/> <input type="checkbox"/> <input type="checkbox"/> <input type="checkbox"/>

Option	Parameter 1 - Station Stop Accel / Decel	ON ▲ 1 2 3 4
1	Slowest	<input type="checkbox"/> <input type="checkbox"/> <input type="checkbox"/> <input type="checkbox"/>
2	Slow	<input type="checkbox"/> <input type="checkbox"/> <input type="checkbox"/> <input type="checkbox"/>
3	Medium	<input type="checkbox"/> <input type="checkbox"/> <input type="checkbox"/> <input type="checkbox"/>
4	Fast	<input type="checkbox"/> <input type="checkbox"/> <input type="checkbox"/> <input type="checkbox"/>
5	Fastest	<input type="checkbox"/> <input type="checkbox"/> <input type="checkbox"/> <input type="checkbox"/>

Option	Parameter 3 - Station Stops	ON ▲ 1 2 3 4
1	100% Always stops (*2* Dual Reed Trolley)	<input type="checkbox"/> <input type="checkbox"/> <input type="checkbox"/> <input type="checkbox"/>
2	75%	<input type="checkbox"/> <input type="checkbox"/> <input type="checkbox"/> <input type="checkbox"/>
3	50%	<input type="checkbox"/> <input type="checkbox"/> <input type="checkbox"/> <input type="checkbox"/>
4	25%	<input type="checkbox"/> <input type="checkbox"/> <input type="checkbox"/> <input type="checkbox"/>
5	0% (Disabled)	<input type="checkbox"/> <input type="checkbox"/> <input type="checkbox"/> <input type="checkbox"/>
6	100% (*1* Single Reed Trolley)	<input type="checkbox"/> <input type="checkbox"/> <input type="checkbox"/> <input type="checkbox"/>
	1 One reed switch will reverse. No intermediate station stops. *2* Two reed switches will reverse, one reed switch will do an intermediate station stop.	

Factory settings

Option	Parameter 4 - Throttle Momentum	ON ▲ 1 2 3 4
1	20 secs 0 to 100% Slowest	<input type="checkbox"/> <input type="checkbox"/> <input type="checkbox"/> <input type="checkbox"/>
2	15 secs	<input type="checkbox"/> <input type="checkbox"/> <input type="checkbox"/> <input type="checkbox"/>
3	10 secs	<input type="checkbox"/> <input type="checkbox"/> <input type="checkbox"/> <input type="checkbox"/>
4	6 secs Fastest	<input type="checkbox"/> <input type="checkbox"/> <input type="checkbox"/> <input type="checkbox"/>

Option	Parameter 6 - Run Time	ON ▲ 1 2 3 4
1	1 Minute	<input type="checkbox"/> <input type="checkbox"/> <input type="checkbox"/> <input type="checkbox"/>
2	3 Minutes	<input type="checkbox"/> <input type="checkbox"/> <input type="checkbox"/> <input type="checkbox"/>
3	5 Minutes	<input type="checkbox"/> <input type="checkbox"/> <input type="checkbox"/> <input type="checkbox"/>
4	10 Minutes	<input type="checkbox"/> <input type="checkbox"/> <input type="checkbox"/> <input type="checkbox"/>
5	15 Minutes	<input type="checkbox"/> <input type="checkbox"/> <input type="checkbox"/> <input type="checkbox"/>

Option	Parameter 7 - Operation Mode	ON ▲ 1 2 3 4
1	Single Track	<input type="checkbox"/> <input type="checkbox"/> <input type="checkbox"/> <input type="checkbox"/>
2	Two Track - Left Keys	<input type="checkbox"/> <input type="checkbox"/> <input type="checkbox"/> <input type="checkbox"/>
3	Two Track - Right Keys	<input type="checkbox"/> <input type="checkbox"/> <input type="checkbox"/> <input type="checkbox"/>

Option	Parameter 8 - Start Interval Timer	ON ▲ 1 2 3 4
1	Disabled	<input type="checkbox"/> <input type="checkbox"/> <input type="checkbox"/> <input type="checkbox"/>
2	15 Minutes	<input type="checkbox"/> <input type="checkbox"/> <input type="checkbox"/> <input type="checkbox"/>
3	30 Minutes	<input type="checkbox"/> <input type="checkbox"/> <input type="checkbox"/> <input type="checkbox"/>
4	60 Minutes	<input type="checkbox"/> <input type="checkbox"/> <input type="checkbox"/> <input type="checkbox"/>

Option	Parameter 13 - User TX Feedback	ON ▲ 1 2 3 4
1	Disabled	<input type="checkbox"/> <input type="checkbox"/> <input type="checkbox"/> <input type="checkbox"/>
2	Transmitter Vibration	<input type="checkbox"/> <input type="checkbox"/> <input type="checkbox"/> <input type="checkbox"/>
3	Not Used	<input type="checkbox"/> <input type="checkbox"/> <input type="checkbox"/> <input type="checkbox"/>

The number of LED flashes indicates the Option Number for the Parameter selected by the DIP switch.

Converting from One Track One Transmitter Operation to Two Tracks on the same Transmitter Operation

When you receive your new second base unit, it should be labeled “Track 1”, with Parameter 7 set for Option 2 (Two Track—Left Keys), Parameter 4 set for Option 3 (10 secs Momentum), and new stickers to label your existing transmitter and base unit. It will be all set to go, except you will need to open it up to “Learn” you existing transmitter. (Press Learn on the PCB then STOP on the transmitter).

Now to set up your existing unit for Track 2 ...

1. Replace the label on your transmitter with the new Two Track label.
2. Open up your base unit and program Parameter 7 for Option 3 (Two Track—Right Keys).
3. Program Parameter 4 for Option 3 (10 secs Momentum, or your choice, but both units should be the same).
4. Place the Track 2 label on your base unit.

Your throttle momentum is now determined by User Parameter 4, so set that as desired.

Adding the Wireless Switch Option

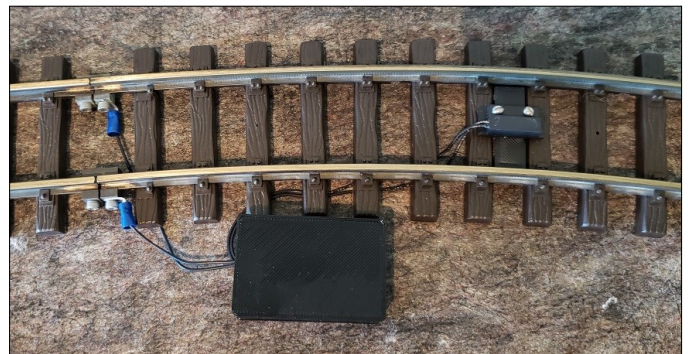
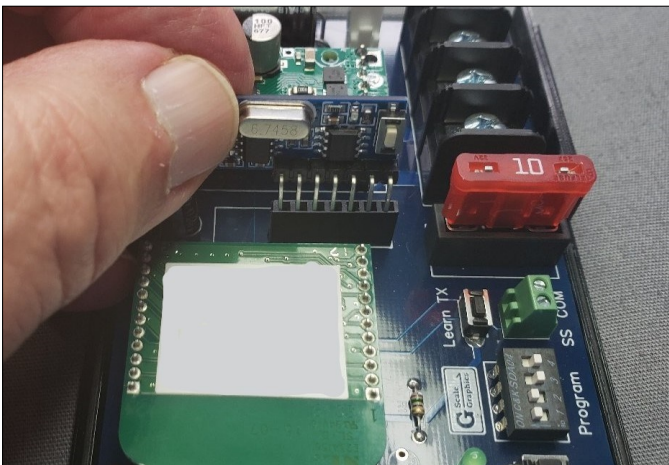

Install the reed switch, transmitter, and magnet

- Insert the reed switch in between rails at desired deceleration point.
- Power the transmitter either directly from the track or any 7-25VDC battery.
- To test, activate reed switch with a magnet. LED on transmitter should blink ON.
- Mount a magnet under the loco or rolling stock such that it just barely clears the top of the rails.

Insert the radio receiver in the socket

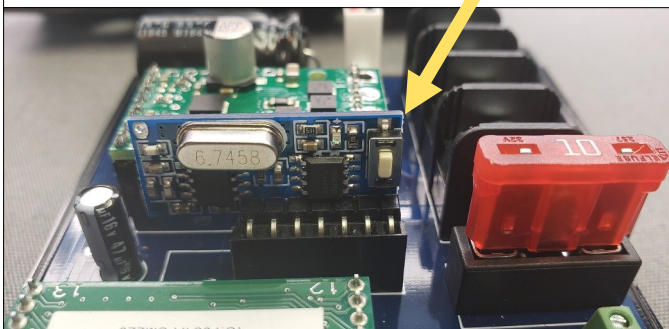

- To learn a new reed switch or start button, press the receiver button to turn on its red LED.
- Then activate the reed switch with a magnet or press the start button. The LED on the receiver should flash 3 times to indicate pairing is complete.
- When loco crosses the reed switch, the LEDs on both the transmitter and receiver should blink ON.

TrackSide 7 R/C - Hardware Specifications

Mechanical

Enclosure

5.5" X 3.5" X 2.6"H

3D printed PETG, Black

Cover/fan assembly removed for access to circuit board via 4 corner screws.

User Connections:

Barrier Strip for Power In, Track Out; accepts 12-22 AWG terminal lugs.

Screw Terminals for Station Stop, Start, Common: accept 26-20 AWG wire.

RailBoss 4 TrackSide Transmitters

2.4 GHZ radio with internal antenna.

Standard TX: 3.25" X 2.5" X 0.9". Two AAAA alkaline batteries.

Waterproof contoured case with recessed buttons under a rubber membrane.

Budget TX: 4.35" X 2.65" X 1.0". Two AAA alkaline batteries. 3D printed case with raised buttons.

Electrical

Power Input (Terminals IN +,-)

7VDC min to 25VDC max, less than 1V p-p ripple.

Reverse polarity protection (prevents damage, but will not operate)

Track Output (Terminals OUT, No polarity)

10 amps max at 100% duty cycle

Fuse, automotive blade fuse, type ATC, 5, 7.5, or 10A

PWM (Pulse Width Modulated), 20 KHZ

Max amplitude: Input voltage minus driver loss

Fan - Runs continuously

Switch Inputs: (internal pullup to 3.3V)

Start: Momentary closure between Start terminal and COM terminal.

Station Stop: Momentary closure between SS terminal and COM terminal.

Radio Rx and Tx

FCC, IC, CE certified and approved. IEEE 802.15.4.

2.4GHZ, Direct Sequence Spread Spectrum, motor noise and interference tolerant, built-in antenna.

Range: Up to 800 ft line of sight.

Warranty - 12 months from date of purchase. Post warranty repairs can be made for a modest fee.



Meanwell Power Supplies

You will need to provide or purchase your own AC power cord and connect it to your Meanwell power supply. Any 3-wire power cord will work. Set the power input switch on the side of the power supply for 115 VAC U.S. Output voltage should be 24 VDC maximum for use with the G-Scale Graphics Trackside R/C or Track Throttle, but no adjustment should be necessary as received.

Meanwell Power Supply

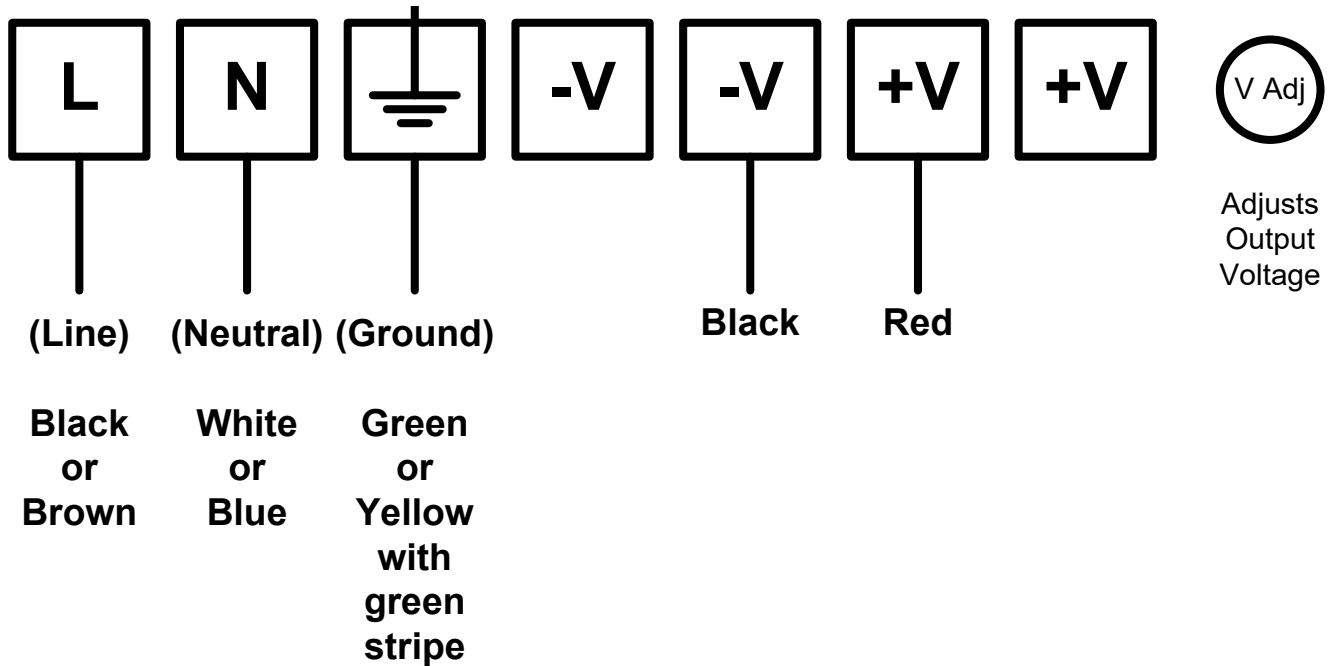

**115 VAC
Input**

VDC Output(s) to Track Throttle(s)

(Set switch on side of power supply for 115 VAC in U.S.)

Crimp some spade connectors on the wire ends for a nice neat connection. The AC input terminals on your power supply may be exposed, so you may want to insert a piece of styrene over them for added safety.

